

## Profile

- Max. resolution 0.4  $\mu\text{m}$
- Works with MB200/1 magnetic tape, MR200 magnetic ring, MBR200 magnetic tape ring
- Reading distance  $\leq 1\text{ mm}$
- IP67 protection category
- Optionally with reference point R or flexible reference marks FR
- Interface LD
- Interface RS485 with Panasonic or Yaskawa protocol

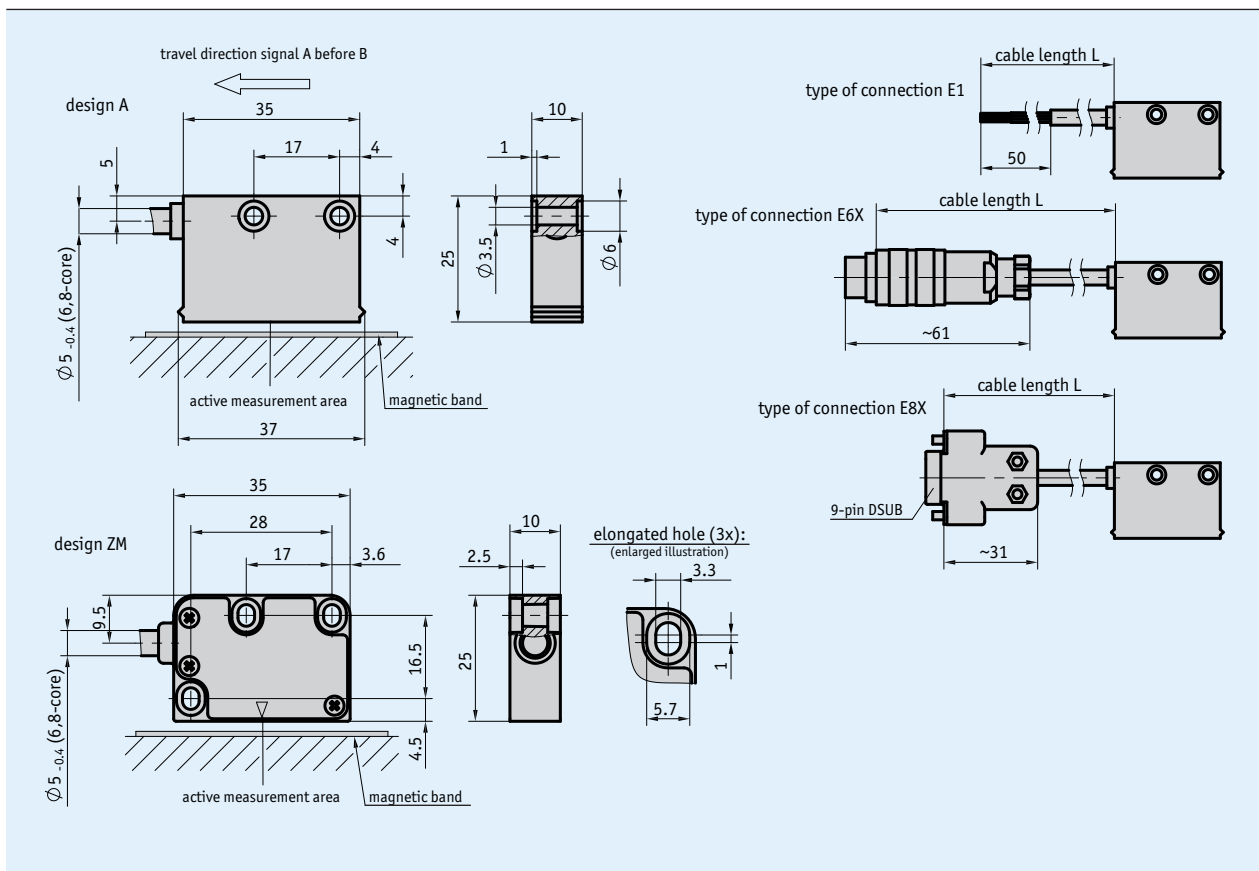
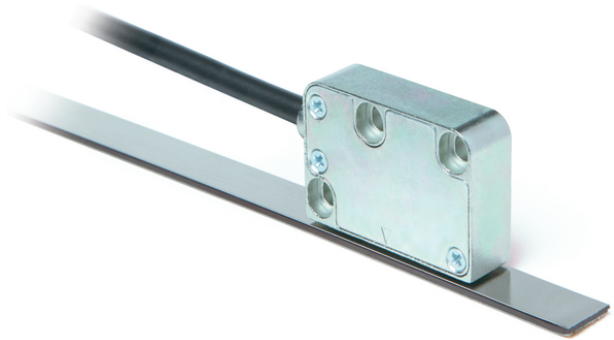

## Mechanical data

Feature	Technical data	Additional information
Housing	green plastic	A design
	zinc die-cast	ZM design
Sensor/band reading distance	0.1 ... 1 mm	O, I reference signals
	0.1 ... 0.5 mm	R reference signal
	0.4 ... 0.5 mm	FR reference signal
Sensor/ring reading distance	0.1 ... 0.8 mm	O, I reference signals
	0.1 ... 0.4 mm	R reference signal
Cable sheath	PUR suitable for drag-chain use	4-core ø 4.4 <sub>-0,4</sub> mm; 6, 8-core ø 5 <sub>-0,4</sub> mm
Cable bending radius	5x cable diameter	static
	7.5x cable diameter	dynamic
Service life of cable	>5 million cycles	under the following test conditions: travel range 4.5 m travel speed 3 m/s acceleration 5 m/s <sup>2</sup> ambient temperature 20 °C ±5 °C

## Travel/circumferential speed

Resolution/ Scaling factor	Travel/circumferential speed Vmax [m/s]						
	0.001/500	6.00	2.40	1.20	0.60	0.30	0.15
0.002/250	12.00	4.80	2.40	1.20	0.60	0.30	
	0.004/125	24.00	9.60	4.80	2.40	1.20	0.60
	0.005/100	25.00	12.00	6.00	3.00	1.50	0.75
0.010/50	25.00	24.00	12.00	6.00	3.00	1.50	
Pulse interval [μs]	0.10	0.25	0.50	1.00	2.00	4.00	
Counting frequency [kHz]	2500.00	1000.00	500.00	250.00	125.00	62.50	

## Electrical data

Feature	Technical data	Additional information
Operating voltage	24 V DC ±20 %	
	5 V DC ±5 %	
Current consumption	≤100 mA	at 24 V DC
	≤30 mA	at 5 V DC
Output signals	A, /A, B, /B, I, /I, R, /R, FR, /FR	
Interface	LD (RS422)	
	RS485/P (Panasonic)	Minas A5, A6
	RS485/Y (Yaskawa)	SIGMA 7
Real-time requirement	speed-proportional signal output	
Type of connection	open cable end	
	plug connector	7/8-pole
	D-Sub	9-pole

## Signal pattern

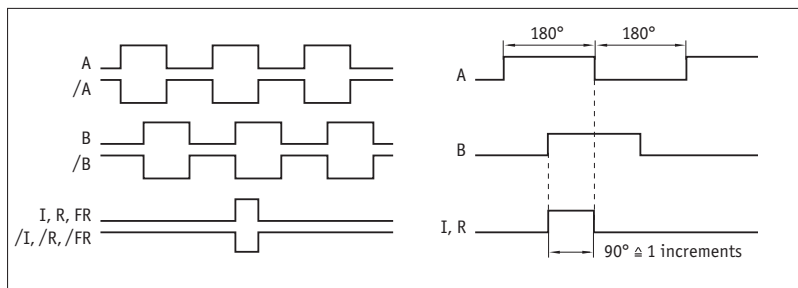

**!** The logical condition of signals A and B is not defined in reference to the index signal I or the reference signal R. It can deviate from the signal form.

**!** Reference or index signal with 4 increments (360°) signal length is only valid from the 5th counting step onwards. A corresponding delay should be taken into consideration after switching on the operating voltage.

■ Pulse interval

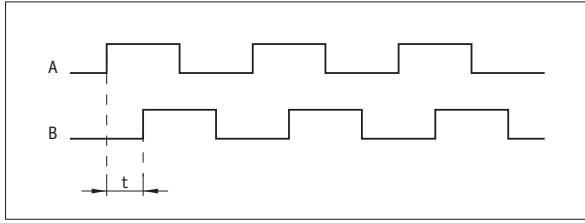

**Example: Pulse interval t = 1 μs**

(i. e., the downstream unit must be able to process 250 kHz)

$$\text{Formula for counting frequency} = \frac{1}{1 \mu\text{s} \times 4} = 250 \text{ kHz}$$

**System data**

Feature	Technical data	Additional information
Resolution	0.0004, 0.0005, 0.001, 0.002, 0.004, 0.005, 0.01, 0.025 mm	
Scaling factor	1250, 1000, 500, 250, 125, 100, 50, 20	
Linearity deviation	±5 μm	at T <sub>U</sub> = 20° C
Repeat accuracy	±1 increment(s)	
Measuring range	∞	
Circumferential speed	dependent on resolution and pulse interval	cf. LD table
Travel speed	15 m/s	RS485/P, RS485/Y
	dependent on resolution and pulse interval	cf. LD table
	15 m/s	RS485/P, RS485/Y

**Ambient conditions**

Feature	Technical data	Additional information
Ambient temperature	-10 ... 70 °C	
Storage temperature	-30 ... 80 °C	
Relative humidity	100 %	condensation admissible
Protection category	IP67	EN 60529

**Pin assignment**

■ Inverted without reference signal, LD

Signal	E1	E6X	E8X
A	red	1	1
B	orange	2	2
nc		3	3
+UB	brown	4	4
GND	black	5	5
/A	yellow	6	6
/B	green	7	7
nc			8
nc			9

■ Inverted with reference signal, LD

Signal	E1	E6X	E8X
A	red	1	1
B	orange	2	2
I, R, FR	blue	3	3
+UB	brown	4	4
GND	black	5	5
/A	yellow	6	6
/B	green	7	7
/I, /R, /FR	violet	8	8
nc			9

■ RS485/P (Panasonic), RS485/Y (Yaskawa)

Signal	Cable color
A	red
B	orange
+UB	brown
GND	white

### Hint for mounting

For systems with reference points on the magnetic tape please take care that sensor and strip are correctly aligned (see picture).

Reference signal	O, I	R	FR
A, Sensor/tape reading distance	$\leq 1 \text{ mm}$	$\leq 0.5 \text{ mm}$	0.4 ... 0.5 mm
B, Lateral offset	$\pm 2 \text{ mm}$	$\pm 0.5 \text{ mm}$	$\pm 0.5 \text{ mm}$
C, Alignment error	$\pm 1^\circ$	$\pm 1^\circ$	$\pm 1^\circ$
D, Longitudinal inclination	$\pm 1^\circ$	$\pm 1^\circ$	$\pm 1^\circ$
E, Lateral inclination	$\pm 3^\circ$	$\pm 3^\circ$	$\pm 3^\circ$

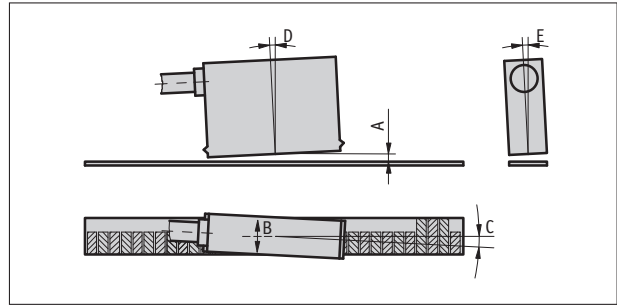

Symbolic representation

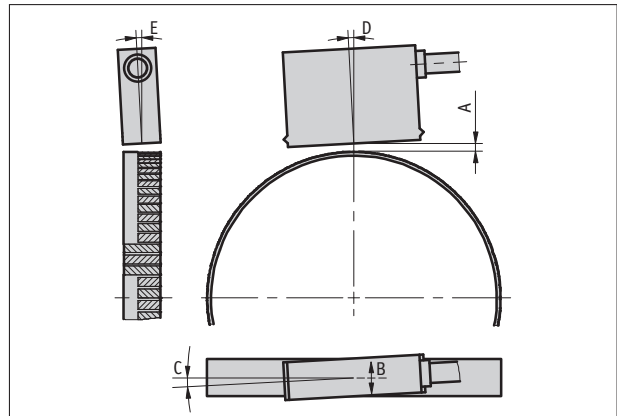

symbolic sensor representation

## Order

### Ordering information

One or more system components are required:

Magnetic band MB200/1  
 Magnetic ring MR200  
 Magnetic band ring MBR200

[www.siko-global.com](http://www.siko-global.com)  
[www.siko-global.com](http://www.siko-global.com)  
[www.siko-global.com](http://www.siko-global.com)

### Ordering table

Feature	Ordering data	Specification	Additional information
Operating voltage	4	24 V DC	
	5	5 V DC	
Design	A	rectangular	
	ZM	metal housing without status LEDs	
Type of connection	E1	open cable end	
	E6X	bullet connector without mating connector	
	E8X	D-SUB 9-pin without mating connector	
Cable length	...	2 ... 20 m, in steps of 1 m	
	D	others on request	
Interface	LD	Line Driver RS422	
	RS485/P	Panasonic	Minas A5, A6
Reference signal	O	without	
	I	periodic index	
	R	fixed reference	
	FR	flexible reference	only for ZM design and with MB200/1 magnetic tape
Linear resolution/ radial scaling factor	...	0.01/50, 0.005/100, 0.004/125, 0.002/250, 0.001/500	
	G	others on request	
Pulse interval	...	0.10, 0.25, 0.50, 1.00, 2.00, 4.00, 8.00	
H			

### Order key

MSK200/1 -  -  -  -  -  -  -  -

A      B      C      D      E      F      G      H

**Scope of delivery:** MSK200/1, Mounting instructions, Sensor fastening set

**Accessories:**  
 Installation aid ZB3054  
 Flexible reference mark

[www.siko-global.com](http://www.siko-global.com)  
 Order key 88678